

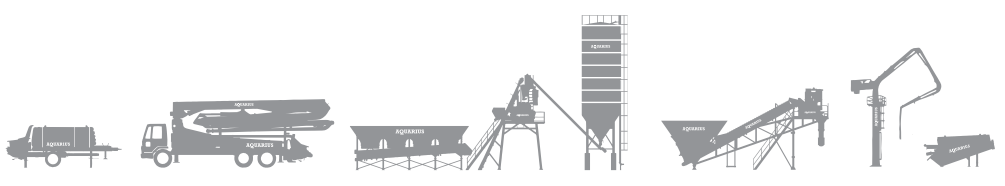

www.aquariusengineers.biz 

AQUARIUS

Trusted since 1997



We Are Aquarius:

Aquarius Engineers is a leading Indian construction equipment company established in 1997.

We take pride in designing and delivering Stationary Concrete Pumps, Truck Mounted Boom Pumps, Concrete Batching Plants and accessories, that meet international quality standards, to Indian and international customers. Our wide range of products are designed using state-of-the-art technologies relevant to the needs of the markets we cater to.

Driven by a clear vision to be the most trusted knowledge and equipment source in the field of concrete production, conveying and placement, Aquarius has grown every year for more than 2 decades. With the same zest and commitment, we pledge to keep improving our products & services to our existing and new customers.

All our machines are designed, produced and validated at our state-of-the-art technology centers at Pune and Goa



Pune Plant



Goa Plant

Works:

Plant I

190, 191 Kundaim Industrial Estate, Kundaim, Goa – 403 115

Plant II

S. No. 480, 481, 482 Ambadwet, Tal. Mulshi, Dist. Pune – 412 111

WAREHOUSE

S. No. 480, 481, 482 Ambadwet, Tal. Mulshi, Dist. Pune – 412 111



About us :

We have State-of-art manufacturing plants at Pune and Goa spread out over 14,000 sq.m. and 40,000 sq.m. of land respectively, focused on manufacturing advanced technology, robust construction equipment, that meet stringent national & international quality standards. Aquarius operates on an all India canvas with regional sales & service offices spread across the country. Aquarius is proud to offer an excellent round-the clock after-sales service and spare part support to our domestic and international customers. Knowledge and safety is a focus area at Aquarius and we offer monthly operator training programs to ensure maximum benefit to customer by ensuring operator and best machine performance at site.

The Management System is Certified by

ISO 9001: 2015	Quality Management System
ISO 14001: 2015	Environment Management System
ISO 45001: 2018	Occupational Health and Safety Management System

The Management System at Pune Factory and Corporate Office is also certified by ISO 9001: 2015

AQUARIUS products also have the following certifications:



CE Certification



SONCAP Certification



AUTHORIZED ECONOMICS OPERATOR-TI CERTIFICATE

Certificate of Recognition ONE STAR EXPORT HOUSE

Products:

- **STATIONARY CONCRETE PUMPS**
 - HIGH PERFORMING SERIES
 - HIGH PRESSURE SERIES
 - ELECTRIC SERIES (VIDYUT)
- **MOBILE LINE PUMPS**
 - **TRUCK MOUNTED BOOM PUMPS**
- **BATCHING PLANTS**
 - COMPACT BATCHING PLANTS
 - COMPARTMENT BIN PLANTS
 - SUPER MOBILE BATCHING PLANTS
 - INLINE BIN PLANTS (SKIP SERIES, CONVEYOR BELT SERIES)
- **STATIONARY BOOM PLACERS**
 - **CONCRETE WASH**





Our Mission:

To bring state-of-the-art technology products, services and expertise to the industry we serve, with a focus on delivering complete and reliable solutions to our customers, with the intention of adding value to their businesses and becoming their long-term partners.



Our Vision:

To be the most trusted knowledge and equipment source in the field of concrete production, conveying and placement in India. To continually invest in better technology, set-ups and engineering, to adopt, upgrade and deliver better solutions to our customers.

Our Values:

Integrity: We will be among the most trusted companies in our area of business. We will be honest, transparent and ethical in our conduct.

Passion for Excellence: Our products and services will aim at harnessing the latest relevant technologies and the highest standards of quality in our area of business, with due consideration to our safety and environmental responsibilities. We will value and promote meritocracy.



Reliability: We will focus on delivering complete and reliable solutions to our customers, with the intention of adding value to their businesses and becoming their long-term partners.

Customer Focus: Our customers are the reason for our success. We commit to listen and respond positively to their needs.

Adaptability: We are open to change and welcome new ideas from our employees, customers and others. We will explore new ways to continually grow our business through teamwork and collaboration.



AATMA-NIRBHAR
BHARAT

वयुधेव कुटुम्बकम्

ONE EARTH • ONE FAMILY • ONE FUTURE

THINK CONCRETE THINK AQUARIUS

TRUCK MOUNTED BOOM PUMP (VIDYUT SERIES)

37 ZX

Boom Pumps



Scan for online catalogue

SALIENT FEATURES

● Applications

- The vidyut series Boom Pump is completely powered by three phase site power for concrete pumping and boom actuation operations
- Machines can be used various settings such as precast casting yards, cement factory sites, aluminum factory sites and various other infra project sites where three phase power is available

● Robust Electric Powertrain

- World's only pure electrical Truck Mounted Concrete Boom Pump—Patent Applied 2024
- The machine uses site three phase mains to power a set of induction motors that drive the hydraulic circuits and operate the machine
- Induction motors are low maintenance, industry recognized and higher efficiency in comparison with diesel engines.
- Enhanced service life due to electric motor
- Enhanced power transmission efficiency due to direct drive

● Fuel-free Operations

- The machine is completely fuel-free for concreting operations
- Zero risk of down time due to fuel shortage or fuel theft

● Flexibility at Site

- Machine comes with a cable reeling drum and 30m of electric cable allowing easy machine relocation on-site
- Reduced erection & commissioning time

● Safe Operations

- Electrical system designed for safety
Electrical and hydraulic interlocks for operator safety
- Centralized diagnostic panel for troubleshooting

● Centralized Oil Lubrication System:

- For selected points & also easy access, manual grease lubrication system to all points

● State-of-the-art Materials

- High strength alloy steel gives maximum strength & performance and minimum weight of the structure

● Robust Open Loop Control System

- Hydraulic system with proven track record in stationary concrete pumps

● Hydraulic Control Block

- Two-handed control of outriggers ensures safe operation

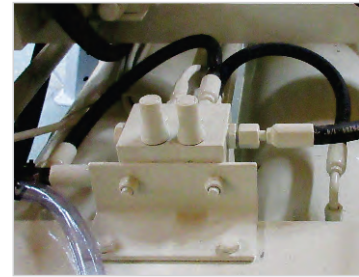

● XEED one side support

- XEED control system allows boom to be operated safely in tight spaces with partial opening of outriggers
- Standard with machine

● Diagnostic Display – Optional

- Diagnostic display on control panel allows to operator to have a complete view of critical machine parameters
- One stop diagnosis station for operator tracking of output per unit (m³/unit) available

● Remote Control

- Cable remote as standard with all machines
- State-of-the-art ergonomic & lightweight cable remote control available on request

● IoT-Optional

- Interactive real-time dashboards of critical machine parameters available, compatible with all mobile devices

● Cable Drum-Optional

- Feasibility of operating away from a power source with the provision of a 30-meter cable mounted on a drum

FLEXIBLE BOOMS

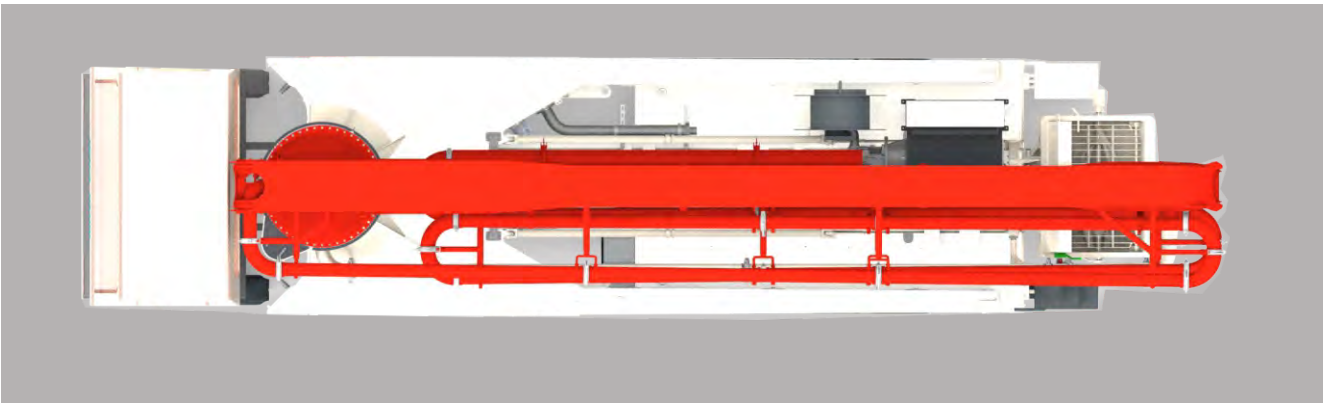

SALIENT FEATURES

- The 'Z' fold boom design facilitates access to tight corners.
- Minimal boom bounce is achieved through the synergy between the boom control valve and the load-holding valve.
- The standard 90° bend in the pipeline helps reduce the intensity.

XEED one side support

The **XEED** System offers additional outrigger combinations allowing safe operation of the boom pump in tight site spaces!

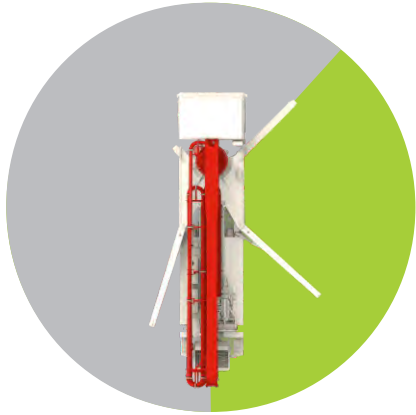

37 ZX
40 ZX
OUTRIGGERS

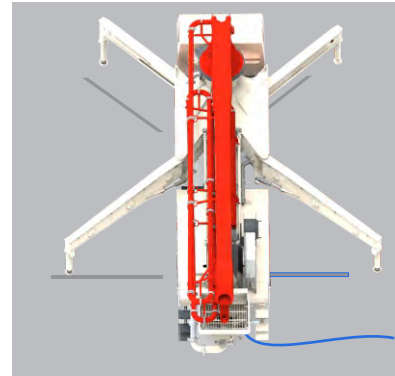

SALIENT FEATURES

- “X” Outriggers provides the best stability for the machine during its operation
- with OSS the boom pump can be operated while supported on one side, providing a good working range of 135° accessible area

Complete Diagnostics

The **Diagnostic Display** is a single user-friendly portal to the operator to view the entire operations of the machine. It helps in fault finding and quick resolution of problems.

IoT-Remote data monitoring

Machine owners can access critical machine operation data and alarms remotely on their wireless devices and be in control of site operations. Fuel and GPS tracking is a valuable addition.

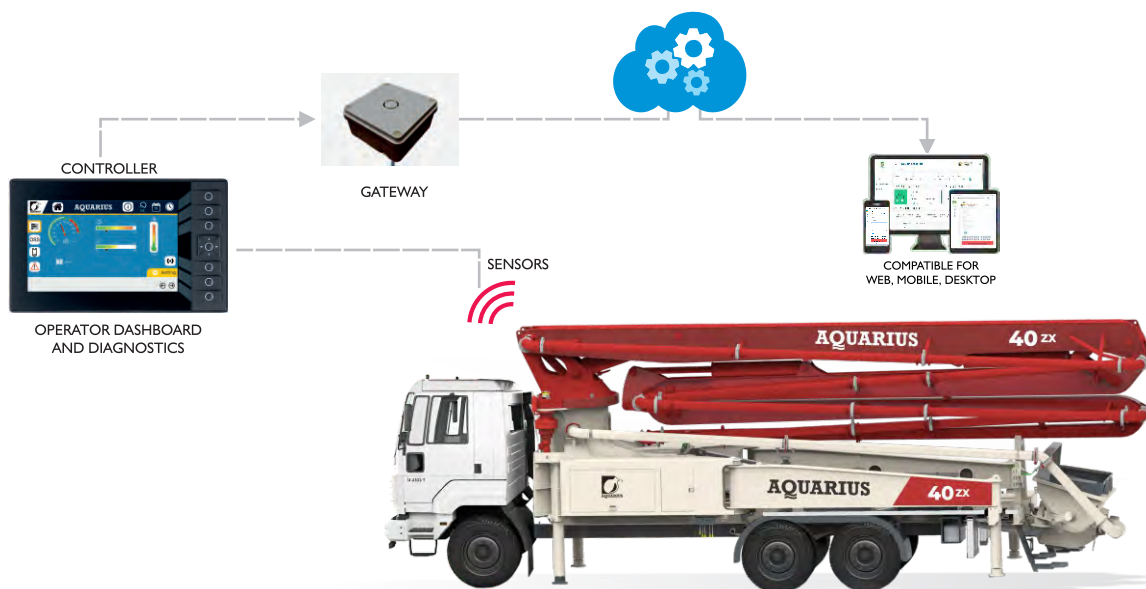

DATA SHEET



BOOM

Parameters	Unit	37.09 ZX
Arms	nos	4
Boom Folding		Z
Chassis Allowable GW	kg	28000
Horizontal Reach (max.)	m	31.82
Vertical Reach (max.)	m	36.75
Reach Depth	m	23.7
Unfolding Height	m	8.4
Slewing Range	Deg.	365°
Delivery Line Diameter	mm	125
Length of End Hose (dn 125)	m	4
Max. Hydraulic Pressure	Bar	360
Electrical System	V	24
Power Drive Electric Motor	kW	90 (Concrete pump)
Power Drive Electric Motor	kW	18.5 (Boom Operation)

*New regulation for two axle chassis (6X4) the GW is specified as 28000kg

CONCRETE PUMP

Model Specification	Unit	37.09
Concrete Output Max. Theoretical	m ³ /hr	85/58
Concrete Pressure Max. Theoretical	Bar	54/80
No. of Strokes / Min	nos	25/17
Delivery Cylinder Diameter	mm	230
Piston Stroke Length	mm	1400
Hydraulic Transmission Ratio (Rod Side)		1:6.5/1:4.37
Easy Clean Hopper Capacity	Ltrs	600
Water Tank Capacity	Ltrs	205

Note: Performance of equipment is based on standard working conditions. Design / Specifications can be changed without prior notice

REACH DIAGRAM

37zx

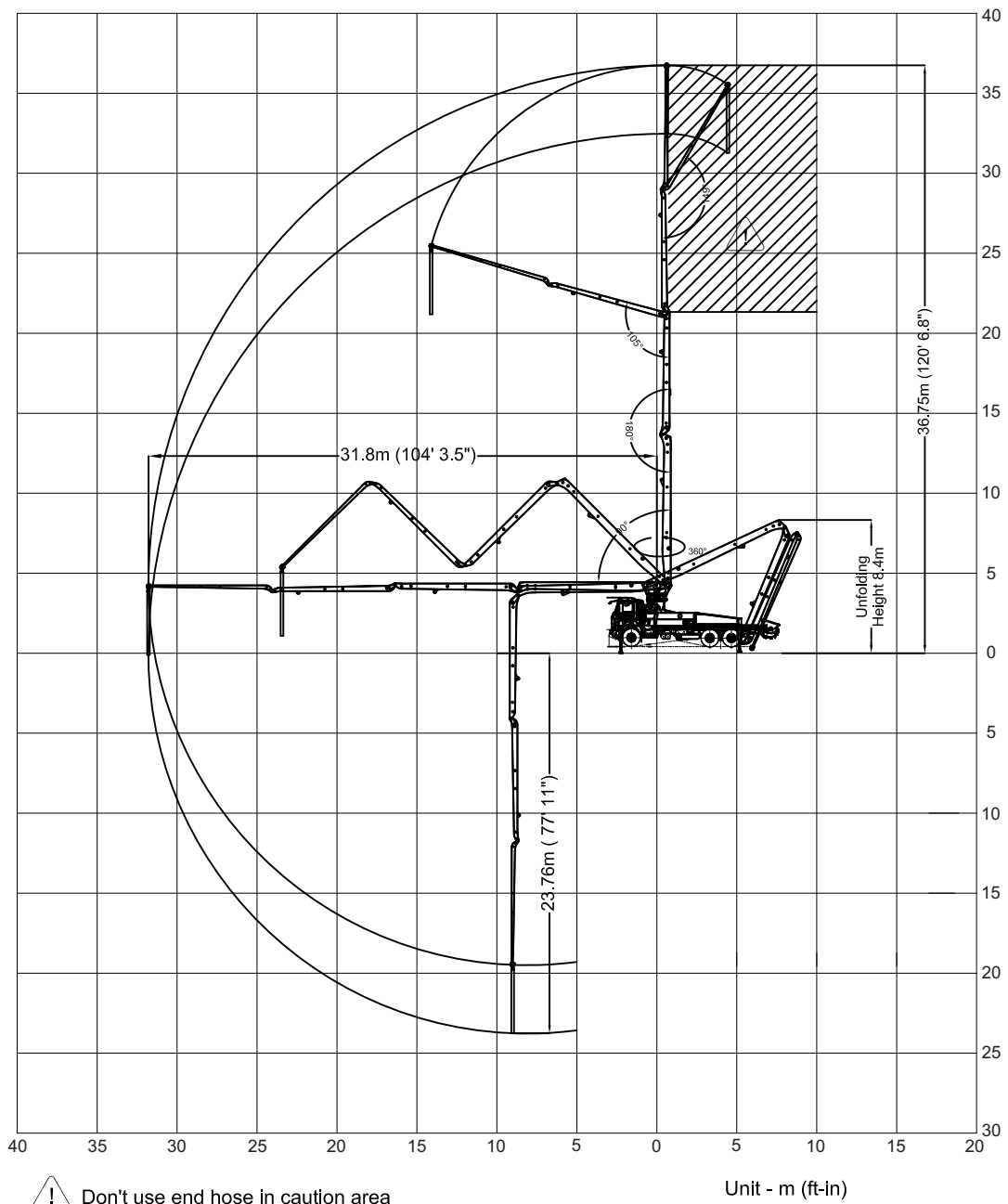
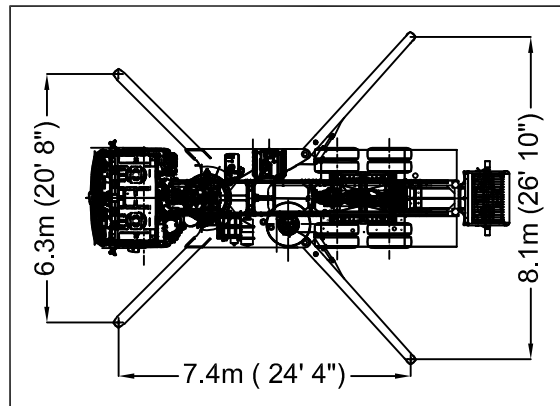

PRODUCT RANGE WITH MODELS

HIGH PERFORMING STATIONARY CONCRETE PUMPS

703 D, 704 D, 1004 D SHP, 1405 D, 1407 D



HIGH PRESSURE STATIONARY CONCRETE PUMPS

1400 HPD, 1400 HPD+, 1407 D HR, 1407 D HR+



VIDYUT CONCRETE PUMPS

1003 E, 1405 E, 1406 E, 1400 HPE, 1400 HRE



MOBILE LINE PUMPS

1004 D SHP MOLI, 1405 D MOLI, 1407 D MOLI, 1407 D HR MOLI



TRUCK MOUNTED BOOM PUMPS

M 20 Z, 37 ZX, 40 ZX



STATIONARY BOOM PLACERS

SB 33, SB 36



COMPACT BATCHING PLANTS

Z 30



COMPACT BATCHING PLANTS

X1, X1.25, X2, X2.5, X3



SUPER MOBILE BATCHING PLANTS

T 21 & T 30



COMPARTMENT BIN PLANTS

MP 30, MP 40, MP 60, MP 70



INLINE BIN PLANTS

SKIP SERIES
SP 30, SP 40, SP 60, SP 70



INLINE BIN PLANTS

CONVEYOR BELT SERIES
SP 60 C, SP 70 C, SP 90 C, SP 120 C



CONCRETE WASH

CW 10



Scan for Product video

OUR NETWORK

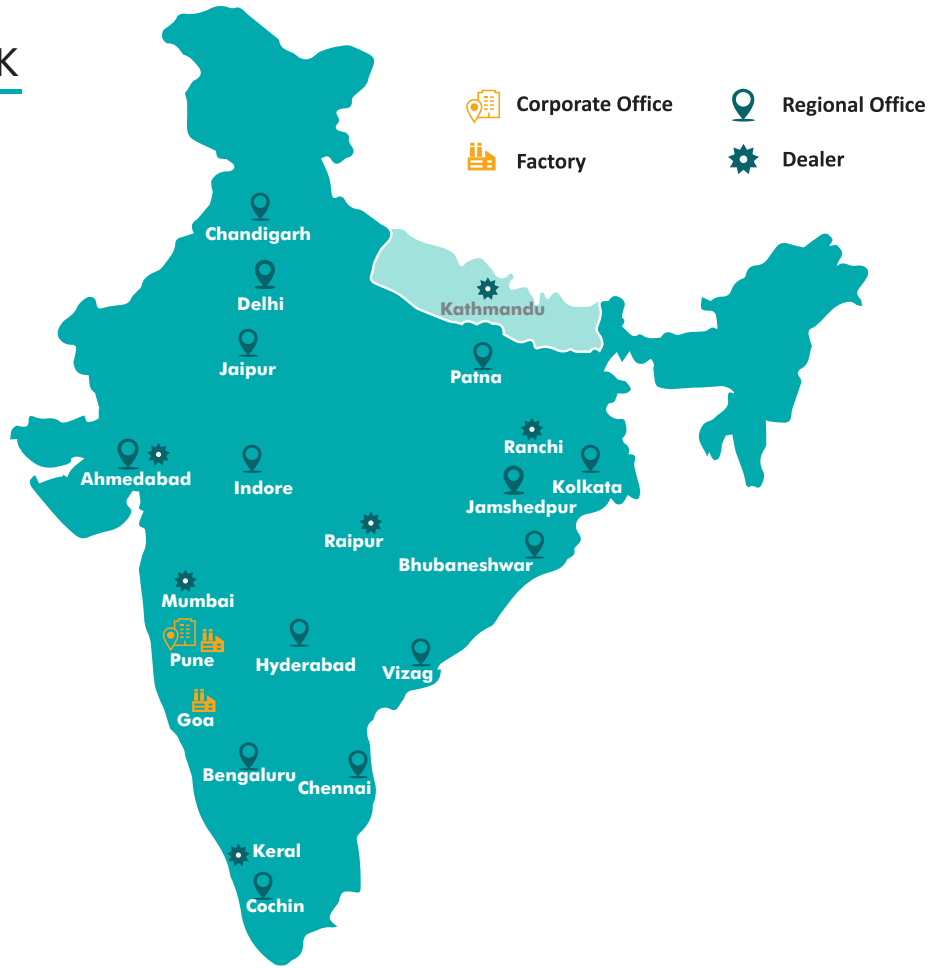

REGIONAL CONTACT DETAILS

Ahmedabad

U-8, B Wing, Samudra Complex, Sardar Patel Colony, Off C. G. Road, Near Girish Cold Drink, Navrangpura, Ahmedabad 380 006

M: + 91 8411020218

Hyderabad

S.Y. No. 400, Plot No. 31 & 32, IDA Kukatpally, Ayanna's Industrial Park, Prashanth Nagar, Hyderabad 500 037 (TG)
Tel.: +91 40 43905241

M: +91 9966629800

Mumbai

W414, T.T.C. Industrial Area, MIDC Industrial Area, Rabale, Navi Mumbai 400 701 Maharashtra

M: +91 8411020218

Cochin

M: +91 9175935704

Goa

M: +91 9326565636

Bhubaneswar

Plot No. D-8, Maitri Vihar, Bhubaneswar 751 016
Tel.: +91 6742301330

M: +91 9372211002

Indore

G-1, Surya Apartment, 193, Anoop Nagar, A. B. Road, Indore 452 008 (MP)
Tel.: +91 731 3074078

M: +91 8411020218

Jaipur

Plot No KC-5, NIZI Khatedari, Narayan Vihar-K, Village Asarpura, Sanganer, Jaipur 302 020

M: +91 9828217557

Pune

M: +91 9371641414
M: +91 9326565636

Bengaluru

No. 1/A, Manjunatha Colony, Third Floor, 24th Main, 5th A Cross, J.P. Nagar, 2nd Phase, Bengaluru 560 078

M: +91 9611655330

Chandigarh / Punjab

SCO-68, Choura Bazaar-2, Chandigarh Ambala Highway, Zirakpur 140 603 (Punjab)
Tel.: +91 7710777186

M: +91 7710777182

Visakhapatnam

Plot No. M-1/I, B- Block, Autonagar, Visakhapatnam – 530012 Andhra Pradesh

M: +91 8977757992 /
+91 9000144063

Patna

M: +91 9163999596

Delhi

Prop No. 27, Ground Floor, Block – 7, Kirti Nagar Industrial Area, New Delhi 110 015
Tel.: +91 11 43306438

M: +91 9873333147

Kolkata

U-1/137, Baishnabghata Patuli Township, P. O. Panchasayar, P. S. Patuli, Kolkata 700 094
Tel.: +91 33 40612128

M: +91 9163999596

Chennai

M: +91 9175935704

Jamshedpur

M: +91 9372211002

Raipur

M: +91 8411020218

Export

M: +91 8390900388

AQUARIUS GENUINE SPARE PARTS

At Aquarius, we strive to excel at and continuously improve our after-sales services and spare parts support. Aquarius is renowned for high-quality spare parts and highly responsive after-sales service. Fast turnaround time is our strength. We have an ERP-backed India-wide spare parts warehouse network, special spares stock for the Indian subcontinent market and an established spares support framework for other international customers.



19+
SPARE PARTS
OUTLETS

Spares Support:
☎ +91 97300 23236

125+
SERVICE
ENGINEERS

Service Support:
☎ +91 77989 86650

OUR INTERNATIONAL FOOTPRINT



8000+ MACHINE POPULATION*

- | | | | | |
|---------------|------------|------------|---------------|-------------|
| 📍 USA | 📍 Canada | 📍 Iraq | 📍 Oman | 📍 Sri Lanka |
| 📍 Algeria | 📍 Colombia | 📍 Kenya | 📍 Philippines | 📍 Somalia |
| 📍 Bangladesh | 📍 DR Congo | 📍 Maldives | 📍 Puerto Rico | 📍 Tanzania |
| 📍 Bhutan | 📍 Gambia | 📍 Myanmar | 📍 Russia | 📍 Togo |
| 📍 Burundi | 📍 Ghana | 📍 Nepal | 📍 Rwanda | 📍 UAE |
| 📍 Benin | 📍 Israel | 📍 Nigeria | 📍 Senegal | 📍 Uganda |
| 📍 South Sudan | 📍 Zanzibar | 📍 Zambia | | |

*Including sales in India



AQUARIUS ENGINEERS PVT. LTD.

Concrete Pumps, Batching Plants, Boom Pumps

An ISO 9001: 2015 Certified Company

'Aquarius House', Sheelavihar Colony, Off Karve Road, Pune 411 038. INDIA

Tel.: +91 20 2544 5227 / 28 Email: enquiries@aquariusengineers.biz

Web: www.aquariusengineers.biz



Follow us on     /aquariusengineers